

## KAR

- Réglage de température par mélange d'air
- Diffuseur d'air à volets intégrés
- 1 seule entrée d'air
- Radiateur performant à boîtes à eau
- Diffuseur orientable à 360°
- Modèle breveté.
- Regulation of the temperature by mixing the air
- Air diffuser with flaps included
- Only one air inlet
- High-performance coil with water boxes
- Rotating diffuser at 360°
- Patented

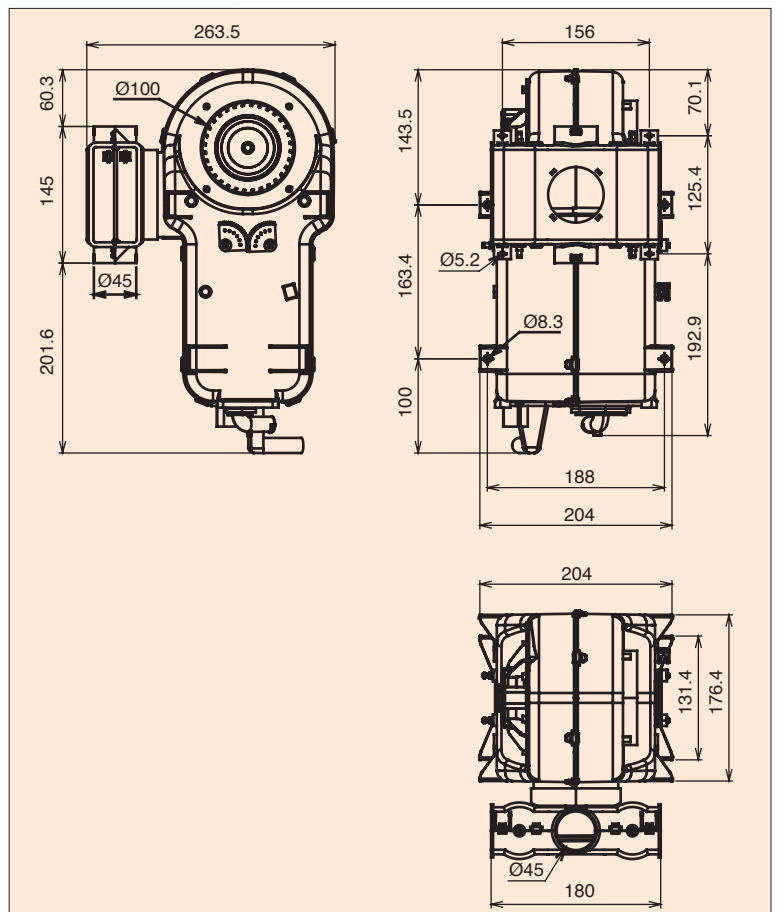

### CARACTERISTIQUES TECHNIQUES TECHNICAL CHARACTERISTICS

TYPE	KAR	
Puissance calorifique Heating output	4200 Kcal/h - 4,9 kW/h	
Débit d'air Air flow	270 m <sup>3</sup> /h	
Raccord sur circuit d'eau Connection to a water system	$\varnothing 16$	
Vitesse de ventilation Speed ventilation	3	
Tension / Voltage	12V	24V
References	120.22.000	120.22.100

